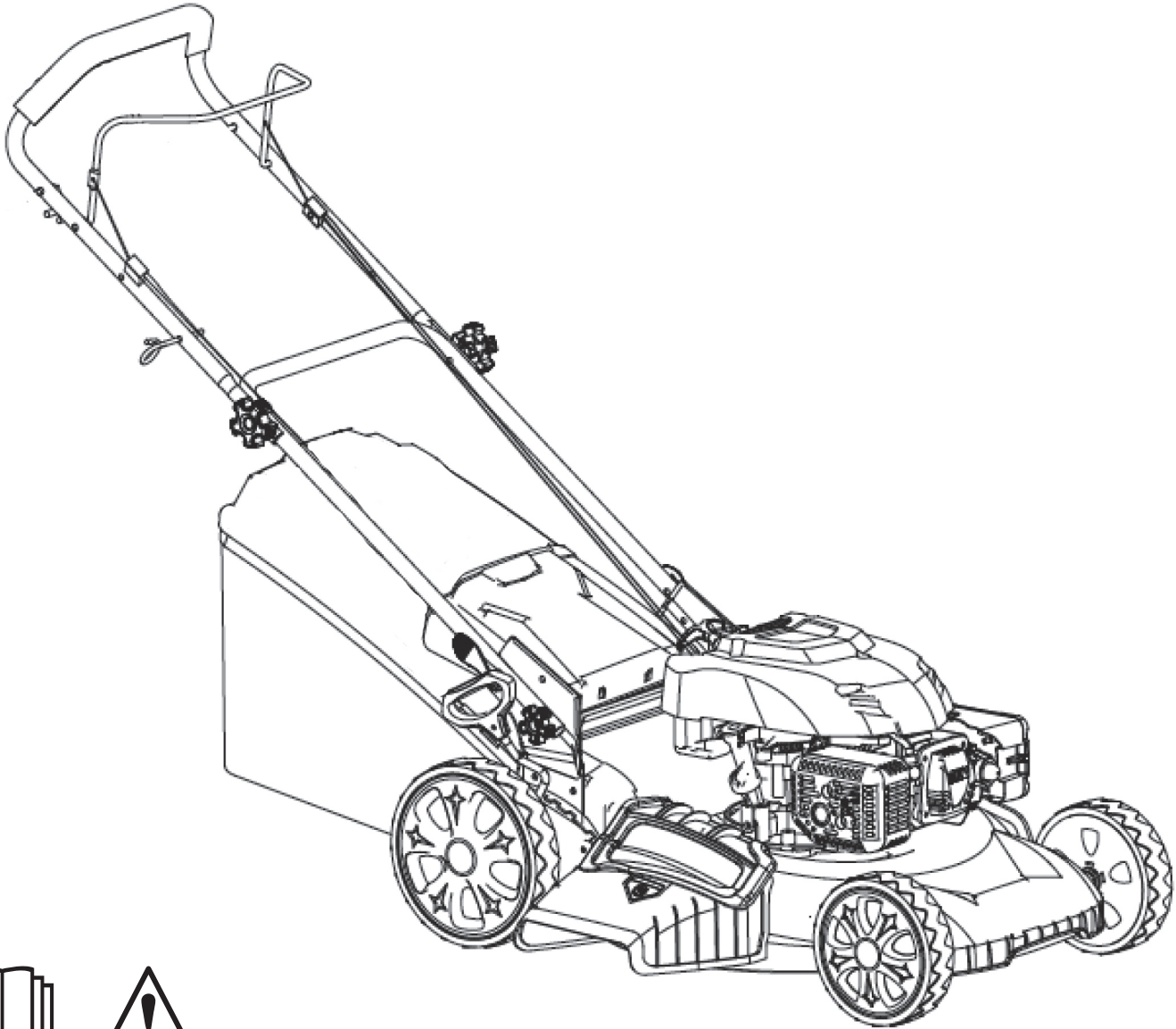




Model#PTG1221

Lawn Mower
OPERATOR'S MANUAL



Warning: The Engine Exhaust from this product contains chemicals known to the State of California to cause cancer, birth defects or other reproductive harm.

INTRODUCTION

Thank you for purchasing this superior quality lawn mower from Pulsar Products Inc. When operating and maintaining this product as instructed in this manual, your lawn mower will give you many years of reliable service.

The emissions control system for this lawn mower is compliant with all standards set by the U.S. Agency.

How to contact us:

To order parts, receive warranty assistance, or other services inquiries, you can contact us at www.pulsar-products.com

PULSAR PRODUCTS INC
2051 S Lynx Place
Ontario, CA 91761
1-866-591-8921

Record the following information bellow for service or warranty assistance.

Date of Purchase:	
Model Number:	
Item Number:	
Serial Number:	



SAVE THIS MANUAL FOR FUTURE REFERENCE

This manual contains important information regarding safety, operation, and maintenance.

TABLE OF CONTENTS

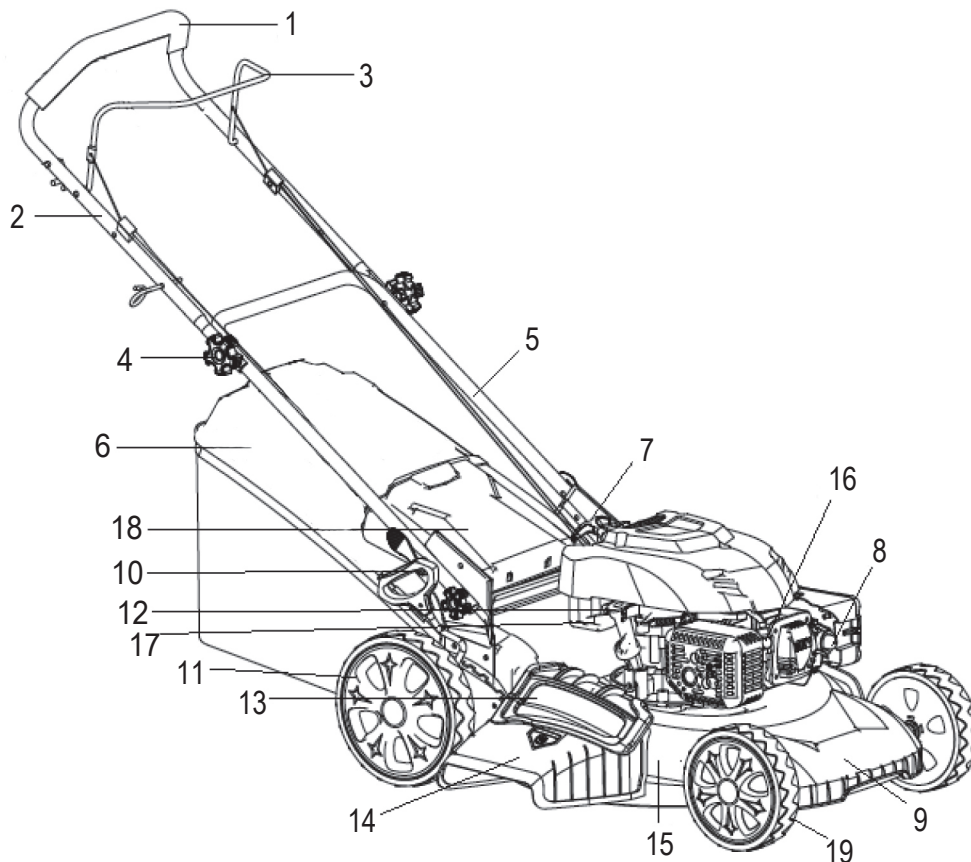
Description of Product Parts.....	3
Technical Specifications.....	5
Intended use.....	6
Safety Information.....	7
Assembly.....	11
Adjustment	15
Operation.....	16
Storing and Maintenance.....	19
Troubleshooting	24
Warranty.....	25

DESCRIPTION OF PRODUCT PARTS

As shown in Fig 1

- | | | | |
|-----|-----------------------------------|-----|----------------------|
| 1. | Soft grip | 11. | Rear wheel |
| 2. | Upper handle | 12. | Engine oil cap |
| 3. | Brake lever /stop lever | 13. | Side discharge cover |
| 4. | Fixing knob with square neck bolt | 14. | Side discharge chute |
| 5. | Lower handle | 15. | Deck |
| 6. | Grass bag | 16. | Spark plug boot |
| 7. | Fuel tank cap | 17. | Pull start |
| 8. | Primer | 18. | Rear discharge cover |
| 9. | Front decorative cover | 19. | Front wheel |
| 10. | Height adjusting handle | | |

Fig 1



DESCRIPTION OF PRODUCT PARTS

As shown in Fig 2

Carefully remove the machine from its packaging and check that the following parts are complete:

- A. Main mower deck (with upper handle and lower handle) 1pc
- B. Cable clip 2pc
- C. Grass bag assembly
- D. Side discharge chute 1pc
- E. Manual 1pc
- F. Big knob with bolt M6 2 pc
- G. Small knob with bolt M6 2 pc
- H. Spark Plug Wrench 1pc
- I. Plastic mulching plug 1pc (inside the mower)

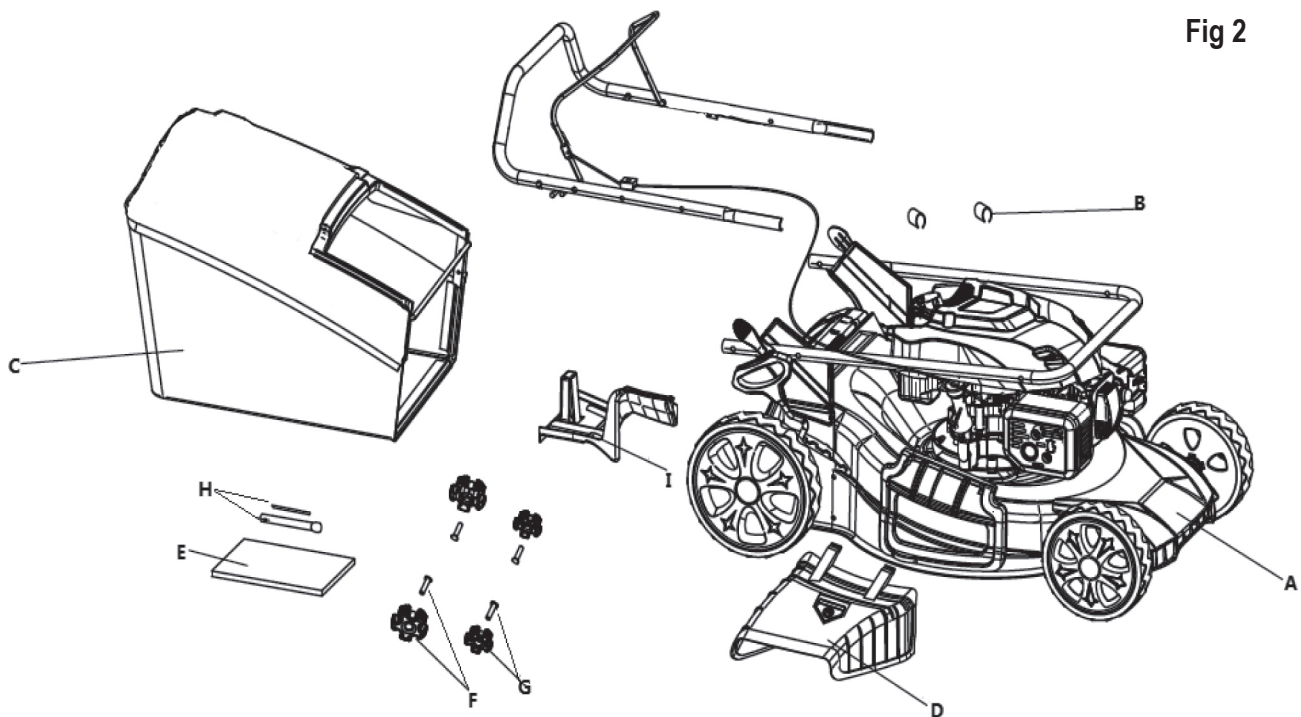


Fig 2

WARNING! If any parts are damaged or missing, do not operate this tool until the missing parts are replaced. Failure to heed this warning could result in serious personal injury.

NOTE! NOTE! Always recycle the packaging in accordance with local recycling laws.

WARNING! This item requires a two person lift to remove from the packaging. Make sure that you have sufficient space to put the lawn mower down. Keep your feet apart so that you have a stable position, bend at the knees and keep your back straight.

TECHNICAL SPECIFICATIONS

Engine Type	Single cylinder 4-stroke
Engine displacement	173 CC
Engine max.power	3.8KW/2800 RPM
Engine speed	2800 RPM
Cutting width	21 Inches/530mm
Grass bag capacity	16 Gallon/60L
Ignition	TCL/TORCH
Fuel tank	0.3 Gallons/1.2L
Oil tank	0.6 Quarts/0.6L
Spark type	RJ9LMC
Net weight	79.3lbs/36KG
Noise Data	
Sound pressure level (LPA)*	84dB(A)
Sound power level (LWA)*	98dB(A)
Uncertainty	3dB(A)
Vibration Data	
Measure vibration emission value	6.1m/s ²
Uncertainty	1.5m/s ²

INTENDED USE

This gas powered lawn mower has been designed for cutting lawn areas in private house and hobby gardens.

The machine is to be used only for its prescribed purpose. Any other use is deemed to be a case of misuse. The user/operator and not the manufacturer will be liable for any damage or injuries of any kind caused as a result of this.

Please note that our equipment has not been designed for use in commercial, trade or industrial applications. Our warranty will be voided if the machine is used in commercial, trade or industrial businesses or for equivalent purposes.

SAFETY INFORMATION

IMPORTANT

Please read these instructions fully before assembling and operating.

Description Of Symbols

Symbols are used in this manual to attract your attention to possible risks. The safety symbols and the explications which accompany them must be perfectly understood. The warning themselves do not prevent the risks and cannot be a substitute for proper methods of avoiding accidents.

Warning Symbols On The Machine



WARNING- To reduce the risk of injury, user must read instruction manual.



This symbol, before a safety comment, indicates a precaution, a warning or a danger. Ignoring this warning can lead to an accident for yourself or for others. To limit the risk of injury, fire, or electrocution always apply the recommendations indicated.



Keep bystanders away



Beware of sharp blades –remove spark plug before maintenance



Never refuel while the engine is running



Risk of injury. Do not open or remove safety shields while engine is running.

SAFETY INFORMATION

Warning Symbols On The Machine



Wearing ear protection, eye protection when operating.



Hot surfaces will burn fingers or palms



Warning! The lawnmower exhaust gas contains toxic substances . Do not run the engine in closed or poorly ventialed areas.



Guaranteed sound power level



Conforms to relevant safety standards.



Waste electrical products should not be disposed of with household waste. Please recycle where facilities exist. Check your local authority or retailer for recycling advice.

SAFETY INFORMATION

Training

1. Read the instructions carefully. Be familiar with the controls and the proper use of the equipment.
2. Never allow children or people unfamiliar with these instructions to use the lawnmower. Local regulations can restrict the age of the operator.
3. Never mow while people, especially children, or pets are nearby.
4. Keep in mind that the operator or user is responsible for accidents or hazards occurring to other people or their property.

Preparation

1. While mowing, always wear substantial footwear and long trousers. Do not operate the equipment when barefoot or wearing open sandals.
2. Thoroughly inspect the area where the equipment is to be used and remove all objects which can be thrown by the machine.



WARNING!

Gasoline is highly flammable.

3. Warning - gasoline is highly flammable.
 - Store fuel in containers specifically designed for this purpose.
 - Refuel outdoors only and do not smoke while refueling.
 - Add fuel before starting the engine. Never remove the cap of the fuel tank or add gas while the engine is running or when the engine is hot.
 - If fuel is spilled, do not attempt to start the engine but move the machine away from the area of spillage and avoid creating any source of ignition until petrol vapours have dissipated.
 - Replace all fuel tank and container caps securely.
4. Replace faulty silencers.
5. Before using, always visually inspect to see that the blades, blade bolts and cutter assembly are not worn or damaged. Replace worn or damaged blades and bolts in sets to preserve balance.
6. On multi-bladed machines, take care as rotating one blade can cause other blades to rotate.

Operation

1. Do not operate the engine in a confined space where dangerous carbon monoxide fumes can collect.
2. Mow only in daylight or in good artificial light.
3. Avoid operating the equipment in wet grass, where feasible.
4. Always be sure of your footing on slopes.
5. Walk, never run.
6. For wheeled rotary machines, mow across the face of slopes, never up and down.
7. Exercise extreme caution when changing direction on slopes.
8. Do not mow excessively steep slopes.
9. Use extreme caution when reversing or pulling the lawnmower towards you.
10. Stop the blade(s) if the lawnmower has to be tilted for transportation when crossing surfaces other than grass, and when transporting the lawnmower to and from the area to be mowed.

SAFETY INFORMATION

11. Never operate the lawnmower with defective guards, or without safety devices, for example deflectors and/or grass catchers, in place.
12. Do not change the engine governor settings or over speed the engine.
13. Disengage all blade and drive clutches before starting the engine.
14. Start the engine or switch on the motor carefully according to instructions and with feet well away from the blade(s).
15. Do not tilt the lawnmower when starting the engine or switching on the motor, except if the lawnmower has to be tilted for starting. In this case, do not tilt it more than absolutely necessary and lift only the part which is away from the operator.
16. Do not start the engine when standing in front of the discharge chute.
17. Do not put hands or feet near or under rotating parts. Keep clear of the discharge opening at all times.
18. Never pick up or carry a lawnmower while the engine is running.
19. Stop the engine and disconnect the spark plug wire, make sure that all moving parts have come to a complete stop and, where a key is fitted remove the key.
 - Before clearing blockages or unclogging chute.
 - Before checking, cleaning or working on the lawnmower.
 - After striking a foreign object. Inspect the lawnmower for damage and make repairs before restarting and operating the lawnmower.
 - If lawnmower starts to vibrate abnormally (check immediately).
20. Stop the engine and disconnect the spark plug wire, make sure that all moving parts have come to a complete stop and, where a key is fitted remove the key.
 - Whenever you leave the lawnmower.
 - Before refueling.
21. Reduce the throttle setting during engine shut down and if the engine is provided with a shut-off valve, turn the fuel off at the conclusion of mowing.
22. Go slow when using a trailing seat.

Maintenance and storage

1. Keep all nuts, bolts and screws tight to be sure the equipment is in safe working condition.
2. Never store the equipment with gas in the tank inside a building where fumes can reach an open flame or spark.
3. Allow the engine to cool before storing in any enclosure.
4. To reduce the fire hazard, keep the engine, silencer, battery compartment and petrol storage area free of grass, leaves, or excessive grease.
5. Check the grass catcher frequently for wear or deterioration.
6. Replace worn or damaged parts for safety.
7. If the fuel tank has to be drained, this should be done outdoors.

ASSEMBLY

Assembling The Handle

As shown in Fig 3&4

1. Fasten the lower handle to the device by using two bolts and two small knobs on each side.
2. Unfold the upper handle and fix it to lower handle by using the big knobs and the bolts on each side

Fig 3

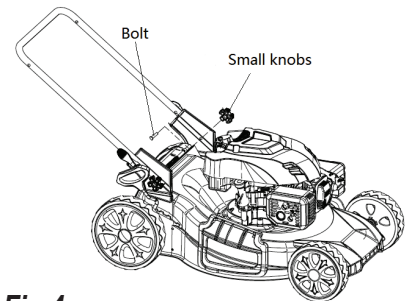


Fig 4

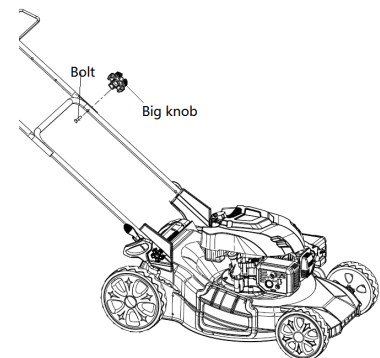


Fig 5

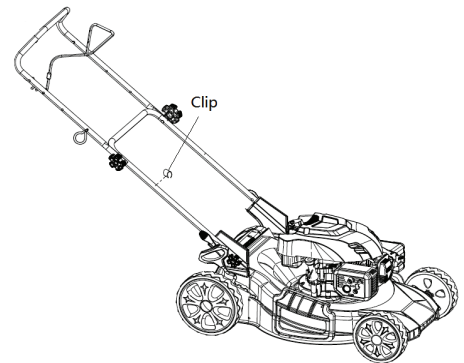
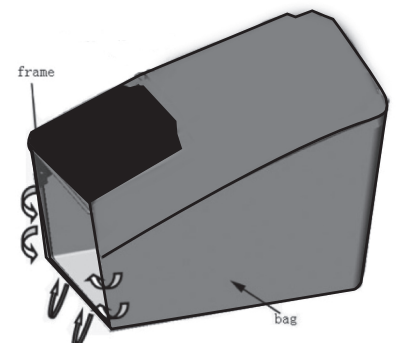


Fig 6



NOTE! Make sure the rope guide is on the right handle, when you stand behind the mower.

Tidy The Connection Cord

As shown in Fig 5

Fix the connection cord to the handle with the cord clip (supplied)

Assembling The Grass Bag

As shown in Fig 6

1. Clip the plastic clips over the metal frame. Make sure that these clips are fully secured to the metal frame.

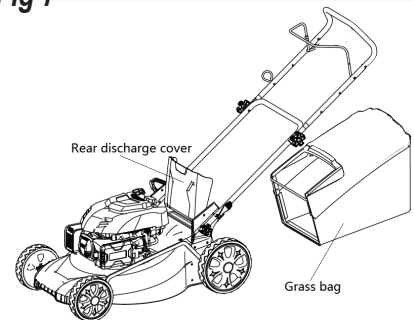
ASSEMBLY

Assembling The Grass Bag Onto The Mower

As shown in Fig 7

1. Lift the rear discharge cover with one hand and hook in the grass bag .
2. Release the rear discharge cover to secure the grass bag in position

Fig 7

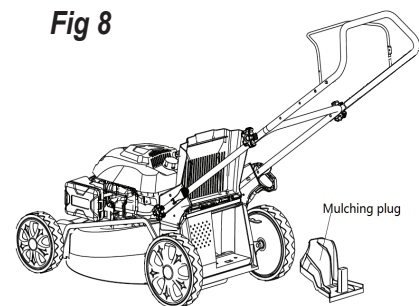


Assembling the mulching plug

As shown in Fig 8

1. Remove the grass bag
2. Push the plastic mulching plug into the discharge chute until it is locked in place.
3. Then release the flap, it will close back to cover the mulching plug.

Fig 8



Assembling the side discharge chute

As shown in Fig 9

NOTE! When using the side discharge function. You need to first remove the grass bag and plug the mulching plug.

1. Lift the side discharge cover with one hand and hook in the side discharge duct with the other hand.
2. Release the side discharge cover to secure the duct in position.

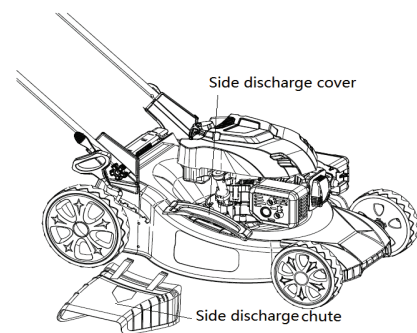


Fig 9

ASSEMBLY

Filling Engine Oil

As shown in Fig 10 -13

CAUTION! The following procedures and adjustments must be performed before the engine is started. Do not attempt to make any of these adjustments while the engine is running.

CAUTION! To prevent engine damage the engine is shipped without oil or fuel. The engine must be filled with the correct grade of oil and fuel before starting the engine.

NOTE! Running the engine with a low oil level will cause engine damage. It is recommend that high detergent, premium quality 4-stroke engine oil used. Using non-detergent oil can shorten the engine's service life and using 2-stroke oil will damage the engine.

CAUTION! Always use high quality detergent oil classified SAE30 oil (or equivalent e. g SAE 10W/30, often termed as 4 Stroke lawn mower oil). Never use additives with recommended oil. To prolong the life of your engine it is important that the oil is changed after the first 5 hours of use.

NOTE! To Check the engine oil level ,stop engine and place the mower on a level surface.

Fig 10

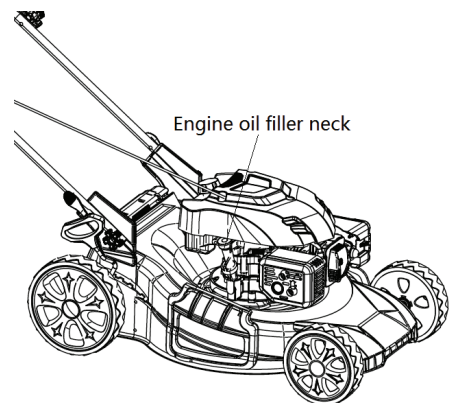


Fig 11

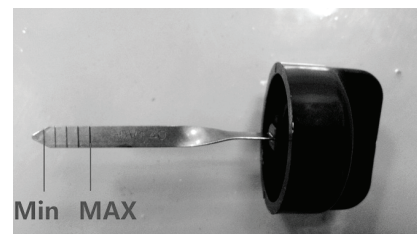
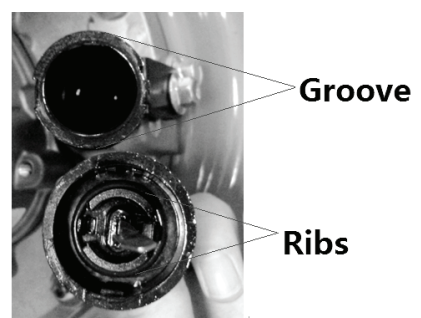


Fig 12



1. Remove the oil filler dipstick and wipe oil from it with a clean cloth.
2. Insert the dipstick into the oil filler neck, but do not turn it in.
3. Then remove the dipstick and check the oil level. The oil level must be between the Min and Max marks on the dipstick. If near the lower level ,fill to upper lever with the recommended oil (SAE30 or equivalent). Do not overfill. Wipe away any spilt oil.
4. Align the ribs of the cap with the groove of the filler neck, then rotate 1/4 turn to secure it.

ASSEMBLY

Filling Engine Fuel

As shown in Fig 13



CAUTION!

Always use clean, fresh unleaded fuel. Purchase fuel in quantities that can be used within 30 days. Never mix oil with gasoline.



CAUTION!

Do not fill into the base of neck to allow for fuel expansion. Do not overfill the fuel tank.



WARNING!

GASOLINE is highly flammable and extreme precaution must be taken when handling or working with it. Keep out of reach of children.



CAUTION!

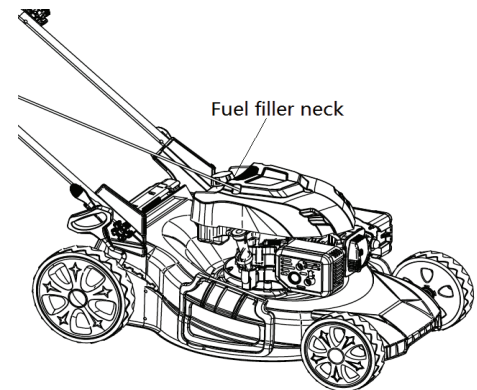
To prevent engine damage the engine is shipped without oil or gas. The engine must be filled with the correct grade of oil and gasoline before starting the engine.



WARNING!

Refuel in a well-ventilated area with the engine stopped. Do not smoke or allow flame or sparks in the area where the engine is refueled or where gasoline is stored. Avoid repeated or prolonged contact with skin or inhalation of vapor.

Fig 13



1. Clean the area around the gas filler cap before removing the cap. Remove the warning tag, check the fuel level.
2. Refill the tank if the fuel level is low.
3. Refuel carefully to avoid overfilling or spilling fuel. There should be no fuel in the filler neck.
4. Clean up any overflow or splashes of petrol before starting the engine.
5. Tighten the filler cap after filling.

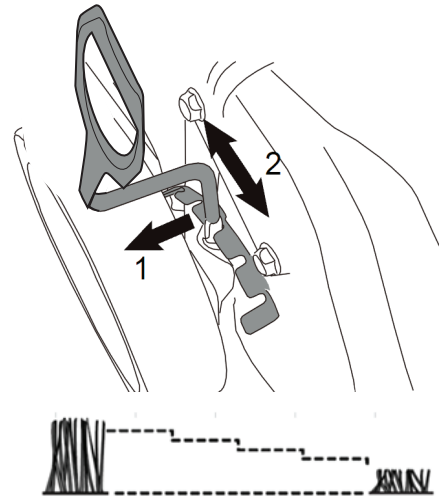
ADJUSTMENT

Setting The Cutting Height

As shown in Fig 14

CAUTION! Adjust the cutting height only when the engine is shut off and the spark plug boot has been pulled.

Fig 14



The cutting height is centrally adjusted with cutting height adjusting handle. Different cutting heights can be selected.

Pull the adjusting handle out and select the desired cutting height. The handle snaps into the desired position.

From position 1 to position 7.

Setting Required Function

CAUTION! This lawn mower has three functions. These functions can be converted by changing accessory setting. Please see the following chart for detail setting.

TO CONVERT MOWER	MULCHING PLUG	GRASS BAG	SIDE DISCHARGE
For rear discharging	x	x	x
For rear bagging	x	√	x
For mulching	√	x	x
For side discharging	√	x	√

“√”: installed “x”: removed

OPERATION

Starting Stopping The Engine

WARNING! The blade begins to rotate as soon as the engine is started.

WARNING! Do not operate the machine in enclosed or poorly ventilated areas as the exhaust gas contains toxic substance. Keep hands, feet, and clothing away from all the moving parts of the machine. The exhaust and other parts of the machine will become hot during use. Make sure that the blade is securely fastened before starting the engine.

NOTE! To start the engine, make sure that the spark plug boot is located on the plug and the machine is filled with sufficient oil and fuel.

To Start The Engine

As shown in Fig 15-16

1. When starting a cold engine, press down the primer fully 3-5 times.

WARNING! **WARNING!** Too much presses on primer May cause engine flooded When starting a warm engine, the primer does not need to be used. If the engine stops due to a lack of fuel, refill and press down the primer 3~5 times.

2. Stand behind the mower. Pull the engine Start/Stop lever toward upper handle with one hand and place the other hand on the pull start.

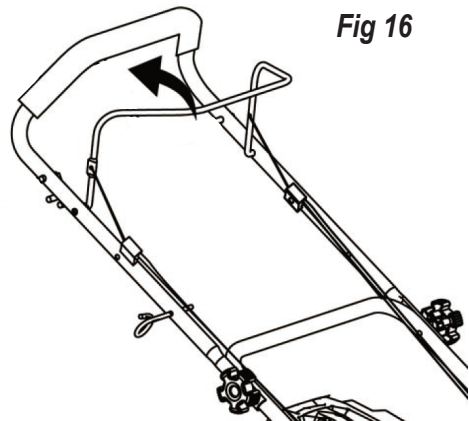
3. Pull the pull start out approx. 4-6 inches until you feel a resistance and then start the engine with a sharp pull.

NOTE! If the engine fails to start after three pulls, repeat the process .

Fig 15

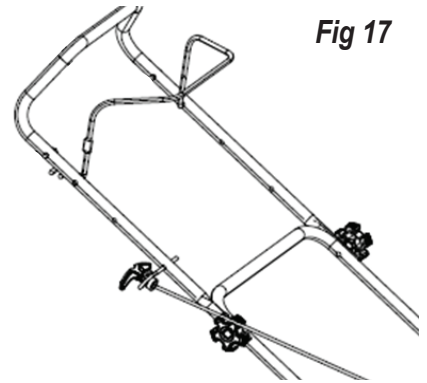


Fig 16



OPERATION

4. Once the engine is running, put the starter rope into the rope guide. As shown in Fig 17



Stopping The Engine

As shown in Fig 18

Release the engine start/stop lever, it will return to its Initial position, the engine will automatically switches off.

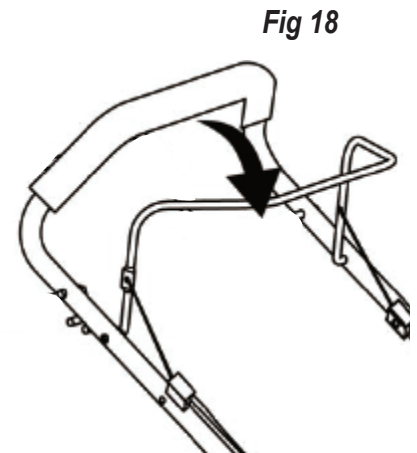
To Clean A Flooded Engine

NOTE! If the engine won't start after you have pulled the starter several times, the engine may be flood with excess fuel. Use following procedure to clear and start a flooded engine.

1. Release the engine start/stop lever to stop engine.
2. Remove the spark plug, dry it, and then reinstall it.

NOTE! Install the spark plug carefully by hand, to avoid cross-threading. After the plug is seated tighten 1/8 to 1/4 turn with socket spanner of spark plug to compress the washer.

3. Pull the engine start/stop lever toward upper handle.
4. Operate the pull start as described above.



OPERATION

Mowing



WARNING!

Always observe the strictest safety procedures when using the lawnmower. Carefully read the safety instructions of this manual before using the lawnmower.



WARNING!

Never open the ejector flap when the grass bag has been detached (to be emptied) and the engine is still running. The rotating blade can cause serious injuries!

1. Select your required setting.
2. Start the engine and allow it run, and set it to required speed. See “to start the engine”.
3. Keep a firm grip on the upper handle with engine stop/start lever and walk along with it to start mowing.

Working Advices

As soon as grass clippings start to trail the lawn mower, it is time to empty the grass bag.



NOTE!

Before taking off the grass bag, switch off the engine and wait until the blade has come to a stop.

1. To take off the grass bag, use one hand to lift up ejector flap and the other to grab onto the carry handle. The ejector flap automatically falls down after removing the grass bag and closes off the rear chute opening.
2. Empty the grass debris in the grass bag, and refit grass Bag.



NOTE!

If any grass residue is caught in the discharge chute, clean it using a brush .Do not remove grass debris in the mower casing or On the blade by hand or with your feet.

Instead use suitable tools such as a brush or broom. To ensure that the cut grass can be collected into grass Bag, the discharge opening and inside the mower casing must be cleared of any blockage.

STORING AND MAINTENANCE

Cleaning



WARNING!

Before performing any maintenance or cleaning work, switch Off the engine and wait until the blade has come to a stop.

General Cleaning

The lawn mower should be cleaned thoroughly every time after it has been used. Always clean your lawnmower immediately after use. Do not allow grass cuttings and other debris to become dry and hard on any of the mower surfaces. Dried grass remnants and dirt may impair the mowing operation.

Check that the grass chute is free of any residual grass. Remove any such residue. Check the underside of the lawn mower and the blade mount . Tilt the lawn mower onto its left side (opposite the oil filler neck)



NOTE!

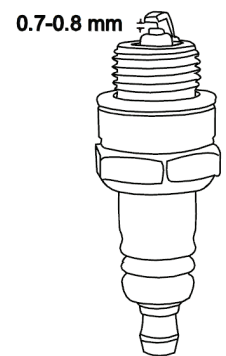
Before placing the lawn mower on its side , fully drain the fuel tank using a fuel extraction pump.

Do not tilt the lawn mower by more than 90 degrees.

Maintenance Of The Spark Plug

1. Once the engine has cooled, pull off the spark plug with a twist.
2. Remove the spark plug using a spark plug wrench.
3. Clean the spark plug with a wire brush (not supplied).
4. Using a feeler gauge set the gap to 0.75mm.
5. Install the spark plug carefully by hand, to avoid cross-threading.
6. After the spark plug is seated, tighten with the spanner to compress the washer.

Fig 20



STORING AND MAINTENANCE

How to Service the Air Filter

As shown in Fig 21

Soiled air filters reduce the engine output by supplying too little air to the carburetor. If the air contains a lot of dust, the air filter should be checked more frequently .

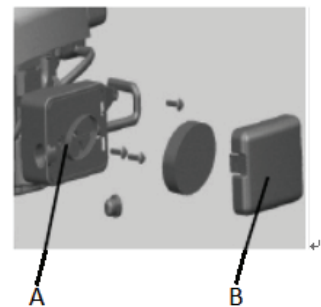


WARNING!

Never run the engine without the air filter element installed.

1. Remove the air cleaner outside cover (A). Be careful to prevent dirt and debris from falling into the air cleaner assembly.
2. Separate the Air Filter (A) from the Air Filter Housing (B).
3. Inspect the air filter. Clean dirty air filter with warm water and mild soap. Allow air filter to dry thoroughly before re-installation
4. Install the air filter assembly onto the carburetor and secure with screw.

Fig 21



NOTE!

Do not use pressurized air or solvents to clean the filter. Pressurized air can damage the filter and solvents will dissolve the filter.

Changing The Engine Oil

Tilt the lawnmower towards the oil filler, have a container ready to catch the oil and remove the dipstick. Once the oil has been emptied, replace the dipstick and wipe clean any spillages.

Refill with 17 oz./500ml SAE30 oil or equivalent i. e SAE5W/30, SAE10W/30. When the dipstick is rested on the filler pipe (i. e . not turn in pace), the oil level must be between the min and max marks on the dipstick.

See “Checking the engine oil level and filling with engine oil ”

Start the engine and allow it to run briefly.

Stop the engine, wait one minute and check the oil level. Top up if necessary .

STORING AND MAINTENANCE

Replacing The Blade

For safety reasons you should only ever have your blade sharpened, balanced and mounted by an authorised service workshop. For optimum results it is recommended that the blade should be inspected once a year.



WARNING!

Before you remove the grass collection bag, stop the engine and wait until the blade stops completely.



WARNING!

You will need garden gloves (not provided) and a spanner wrench(not provided) to remove the blade.



NOTE!

Don't invert the mower. Tip it slightly towards the oil filler pipe and reach under the deck.



WARNING!

Always handle the blade with care, sharp edges could cause injury **USE GLOVES**. Renew your metal blade after 50Hrs mowing or 2yrs whichever is sooner regardless of condition.



WARNING!

If the blade is cracked or damaged replace it with a new one.



WARNING!

Don't hold the blade by with your bare hand.



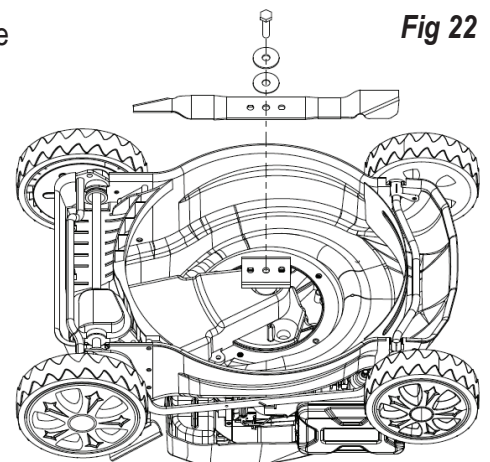
NOTE!

Maintain the sharpness of the blade when cutting grass. If the blade has worn excessively and become pitted and blunt, it should be replaced or sharpened. The sharpness of the blade will affect the performance of the lawnmower.

For safety reasons we recommend that the blade only be changed by someone qualified and authorized to do so.

Hold the blade and unscrew the blade bolt counterclockwise using a spanner wrench. Remove the washer and the blade.

Fit a new blade or re-sharpen the blade, locate the blade on the two studs on the blade flange and then replace the washer and bolts. Make sure the blade is correctly located, and then firmly tighten the bolt. Do not over tighten. The up turn of the blade must project into the motor compartment.



STORING AND MAINTENANCE

Storing the Lawnmower for Short Periods

The lawnmower can be stored for short periods of time (less than 15 days) without performing any storage maintenance. Before placing the lawnmower into storage always carry out the following:

1. Allow the engine to fully cool.
2. Ensure the grass bag is empty.
3. Clean all debris from under the mower deck.
4. Store the lawnmower on flat and level surface with the mower upright.
5. Store in a safe place which is not accessible by children or people who are not familiar with operation.

Storing the Lawnmower for Extended Periods

If the lawnmower is to be placed into storage for more than 15 days, storage maintenance must be performed on the lawnmower. If the following steps are not carried out, when you next operate the lawnmower it may not start correctly and may need to be serviced.



CAUTION!

Do not empty the fuel tank in enclosed areas, near fire or when smoking. Gasoline fumes can cause explosions and fire.

1. Empty the gas tank with a gasoline suction pump if available.
2. Start the engine and let it run until any remaining gasoline has been used up.
3. Change the oil at the end of every season. To do so, remove the used engine oil from a warm engine and refill with fresh oil.
4. Clean the cooling fins of the cylinder and the housing
5. Be sure to clean the entire machine to protect the paint.
6. Store the machine in a well-ventilated place.

STORING AND MAINTENANCE

Maintenance Schedule

Performing routine maintenance correctly on your lawnmower will ensure you get years of trouble free use.

Please keep this manual safe for future reference.

It is recommended that the following maintenance schedule is adhered to. This will ensure the lawn-mower operated correctly and is safe to use.

	12 HOURS OF USE	24 HOURS OF USE	36 HOURS OF USE
Air Filter	Clean	Clean	Replace
Spark Plug	Check	Clean	Replace
Engine Oil	Check	Replace	Check

The Engine oil should be changed after the first 8 hours.

Transport

Empty the gas tank.

Always let the engine run until it has used up the remainder of gas in the tank.

Empty the engine oil from the warm engine.

Remove the spark plug boot from the spark plug.

Clean the cooling fins of the cylinder and the housing.

Use the original packaging to ship whenever possible.

TROUBLESHOOTING



WARNING!

Before performing any maintenance or cleaning work, switch off the engine and wait until the blade has come to a stop.



CAUTION!

Improper repairs can result in the product functioning unsafely. This endangers yourself and your environment.

Faults which cannot be rectified with the aid of following table may be rectified by a specialist company only (customer service center) 1-866-591-8921.

Please be aware that any improper repairs will also invalidate the warranty and additional costs may be incurred.

Use only genuine spare parts. Only these spare parts are designed and suitable for the product. The use of other spare parts not only voids the warranty, you can also endanger yourself and your environment.

FAULT/MALFUNCTION	CAUSE	SOLUTION
Loud while running, machine vibrates heavily	Screws are loose Blade fasteners are loose Blade is unbalanced	Check screws Check blade fasteners Replace blade
Engine does not start	Start/stop lever not pressed Spark plug is defective Fuel tank is empty Engine may be flooded	Replace spark plug Call customer service center Refill with fuel Remove plug and dry
Engine runs unsteadily	Air filter is soiled Spark plug is soiled	Clean the air filter Clean the spark plug
Uneven mowing results	Blade is blunt Cutting height is too low	Sharpen the blade Set correct height
Grass bag is not filled sufficiently	Blade is worn Grass bag is clogged Cutting height is right? The lawn / grass is wet ? Does the discharge channel/ housing blocked ? Does underside of the mower deck have been clogged?	Replace the blade Empty the grass bag Correct the cutting height Allow the lawn to dry Clean the discharge channel/ housing Clean the underside of the mower deck

WARRANTY

PULSAR PRODUCTS Limited 1 Year Warranty:

From the date of original purchase, Pulsar Products Inc. warrants to the original purchase, that each Lawn Mower sold, shall be free from defect in material and workmanship for a period of 1-year on all components.

Pulsar Products Inc., at its discretion, agrees to repair or replace any defective part that upon examination, inspection, and testing by a Pulsar Products Inc. authorized service dealer, is found to be defective within the original warranty period. Pulsar Products Inc. will also decide upon the use of new or rebuilt parts or comparable product. Any part or product that is replaced will be retained by Pulsar Products Inc. This warranty period shall not be extended and any repaired product shall be warranted for the remaining period of the original warranty. The consumer is responsible, and shall prepay all transportation costs, including returning items to the factory or warehouse. This warranty is not transferable and proof of purchase must be presented when requesting warranty service. If a proof-of-purchase receipt is not provided, the product's shipping date by the manufacturer will be used to determine the warranty period.

Where Warranty is Valid:

For warranty coverage, this product must be purchased from an authorized Pulsar Products Inc. dealer and the warranty only extends to the original purchaser in the United States, Canada, or Mexico. Refurbished, used, demonstration, or floor models are not covered by this warranty. Products purchased from on-line auction websites, such as ebay, are not covered under this warranty. Products used for commercial use are not covered under this warranty.

Consumer Responsibilities:

- Consumer is responsible for carefully reading and following all instructions in the owner's manual. Any product that is damaged due to misuse or abuse will not be covered by this warranty.
- Consumer is responsible for all transportation costs to an authorized Pulsar Products Inc. Service Center. Unless otherwise requested, ground shipping will be applied for part shipment and customer will pay any additional charges for expedited shipments.
- Consumer is responsible for labor costs associated with warranted repairs twelve (12) months after the purchase date. Labor rates will only be based on normal working hours.
- Consumer is responsible for maintaining the lawn mower as specified in the owner's manual. Documentation of this maintenance may be required to cover warranty requests.
- Consumer is responsible for presenting any problems with the pressure washer to an authorized Pulsar Products Inc Service Center as soon as the problem exists. Warranted repairs will be completed in a reasonable period of time, not to exceed 30 days.

What is covered under this warranty:

Replacement parts and labor. Please note that we reserve the right to repair or replace the product as we deem appropriate.

WARRANTY

What this Warranty Does Not Cover:

- **Normal wear:** This warranty excludes normal wear items unless under normal use, the original equipment is defective in material or workmanship and needs to be replaced prior to the first replacement interval.
- **Maintenance:** This warranty does not apply to routine maintenance and does not cover any adjustments or repairs not performed by an authorized repair facility.
- **Misuse:** This warranty does not apply if your product has failed due to abuse, misuse, neglect, improper maintenance, improper storage, unapproved modifications, or has been operated in any way contrary to the instructions found in the products owner's manual.
- **Adverse conditions:** This warranty does not apply if your product has failed due an accident or natural disasters.
- **Product Shipment:** This warranty does not apply to damage resulting from shipping, handling, or warehousing: Any damage claims to this product caused by shipment must be filed with freighter.
- **Damage to property:** This warranty does not include consequential damages, incidental damages, or damage to property.
- **Other exclusions:** This warranty does not apply if your product has been sold "as is" or where the factory applied serial number has been removed. Refurbished used, demonstration or floor models are not covered by this warranty.

How to Obtain Warranty Service:

Take the original receipt and product to the place of purchase or mail the original receipt and product to the address found on the web site if purchased on-line. You can also locate your nearest Pulsar Products Inc. dealer for service or warranty questions by calling toll free at 1-866-591-8921 Mon-Fri 7:00 AM to 4:00 PM Eastern Standard Time.

Customer Support:

Product owners are welcome to contact customer support at 1-866-591-8921 with any questions and concerns they might have. During the duration of the warranty, the following services are provided to the consumer:

Guidance: - The service center will answer operational, technical, and maintenance questions for simple procedures that the customer feels they can safely perform.

Parts: - If a customer needs a part that can be self-installed, that part will be shipped free of charge. Ground shipping will be applied for part shipment. The customer will be responsible for any additional charges for rush shipments. If the product is no longer under warranty, the customer may purchase parts and will be responsible for all shipment costs.

Service Center: - Customers may take their product to an authorized service center for servicing or repairs. Transportation or shipment costs of the unit will be the responsibility of the customer. To set up a service appointment with a service center nearest you call -866-591-8921. To streamline scheduling, service centers do not offer warranty service without an appointment.

PULSAR PRODUCTS INC.'S OBLIGATION UNDER THIS WARRANTY IS EXCLUSIVELY LIMITED TO PRODUCT REPAIR OR REPLACEMENT AND SHALL NOT BE LIABLE FOR ANY INCIDENTAL OR CONSEQUENTIAL DAMAGES INCLUDING BUT NOT LIMITED TO THE EXPENSE OF DELIVERING PRODUCT TO AND FROM REPAIR CENTER, LOSS OR DAMAGE TO PERSONAL PROPERTY, LOSS OF REVENUE, TELEPHONE CHARGES, LOSS OF TIME, OR INCONVENIENCE. SOME STATES, PROVINCES, OR JURISDICTIONS DO NOT ALLOW THE EXCLUSION OR LIMITATION OF INCIDENTAL DAMAGES, SO THE ABOVE LIMITATION MAY NOT APPLY TO YOU. THIS WARRANTY GIVES YOU SPECIFIC LEGAL RIGHTS, AND YOU MAY ALSO HAVE OTHER RIGHTS WHICH VARY FROM STATE TO STATE OR PROVINCE TO PROVINCE.